

Well done you have finished the panels....

Points to note as you construct your shed:

- **Do not** attempt to assemble panels in windy conditions
- **Make** sure your foundations are squared and level before erecting panels.
- **It is** easier to remove all swarf (filings) before you stand your walls up
- Complete **all** panels before erecting your shed.
- Keep a firm grip on panels when handling. If they slip they will cause damage.
- Always wear non slip gloves protective footwear and eyewear.

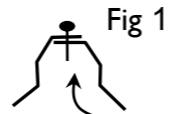

5: Now to join your corners and put your roof on....

1st: Stand up the back wall and as your helping hand is holding it up bring the one end wall into meet it at the left corner overlapping the corners as Fig 1. Drill & Fix at approx 100mm down from the top and up from the bottom drilling and fixing from the outside. Make sure the walls are sitting flat and flush at the bottom.

2nd: Bring the other end wall into the right back corner and perform the same again checking the bottoms are flush

3rd: Bring the front wall into place and join the front corners to the end walls same as the back.

4th: Finish joining corners by fixing at approx 300mm apart. You will find it easier to drill these corners if they are supported on the inside. Use the handle end of a hammer into the inside of the corner, but beware of drilling holes in the end of your hammer.

5th: With a person at each end of the roof panel with the Ridge beam attached, waft it over top of your upright walls and lower down on top. Have your helping hand go inside and make sure the roof panel is centralised by having the ridge beam sitting right on the apex of the channel at the peak of the end wall. Fix the "L" thru the top channel to both end walls at the 1st rib in from the lowest corner making sure it is still centralised. The ridge beam will not be held down at this stage.

6th: Now waft the 2nd roof panel onto the walls, slipping it into the ridge beam. Make sure it is sitting firmly into ridge beam and then fix it to the inside flange of the ridge up underneath. (Fig 2) Now finish off fixing the "L"s to the top channels at both ends. Fix at 300mm apart and also thru end of ridge beam into "L"s. If you find the roof is binding and not wanting to sit squarely on the walls, this will be caused by unlevel site or walls are not square. Adjust accordingly.

7th: Using your ladder and tape measure, fix down thru the top of the roof, thru the pan into the top channel of front and back walls. (10mm more than the overhang). Fix beside every 2nd rib. (Fig 3). You will not need to worry about these fixings leaking as any water seeping thru these fixings will end up on the outside of the walls.

8th: Attach padbolt to door strap and fit door braces if not already done so. Check that all swarf is removed and most importantly....

9th: Fix your shed down to its foundations. If your foundations are unlevel or bowed, you will have problems with your padbolt and door levels. This can be fixed by slipping a spade under either door jamb and lifting. You will soon get a feel for which side needs propping up.

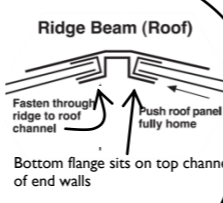
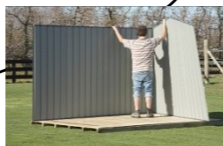
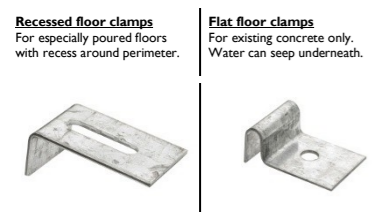

Fig 2



It is **utmost** essential that every shed has a floor, but the only way to make sure your shed is there to stay on windy sites is with a recessed concrete floor and phone **0800 80 SHED** for more free advise.

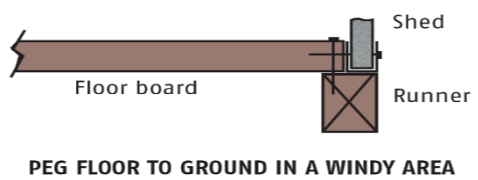

Fig 3

Feedback....

As we are forever trying to make sure you are our happiest customer, we are always on the look-out for ways in which we could do better. Please fax us on **06 878 5758** or send us an email to feedback@gardenmastersheds.co.nz with your thoughts. To help you we have listed a few aspects that we would like you to comment on. You do not have to include your details, but if you do we will forward you a **free gift**.

1. Finding out about our range of garden sheds and the various options we offer....
2. The store and the sales person that you purchased from....
3. The delivery and the overall dealings for the purchase of your shed....
4. The assembly of your shed and clarity of instructions....
5. Did the shed fit your needs? What will you order differently next time?



GM3830 - Gable Roof Shed
3770mm W x 3030mm D x 1830 - 2090mm H
ASSEMBLY INSTRUCTIONS
"This shed has 1 Box and 1 Channel pack"

What tools will I need?

- Drill and drill bits - 3.3mm (1/8th") for shed and 5mm (3/16th") for padbolt
- Screwdriver or Riveter. (Note: all colour sheds come with rivets only)
- Tape measure for roof overhang.
- Ladder for fixing down thru the top of the roof.
- Tin snips for a small nik on top channel of gable end walls only.
- Non slip gloves, good shoes, goggles, a helping set of hands and **no** gusty winds!



Quick Tips to keep in mind as I build my shed:

- Try to remove swarf (drill filings) from panels as I assemble them.
- My basic job is to cap the sheeting to make the panels. Drill & Fix.
- All components are cut to length. **Do not** cut any parts unless instructed.
- They are only a phone call away **0800 807 433** or email to info@gardenmastersheds.co.nz
- Fixings thru the **inside** of the channels into the sheeting are just as **important** as the **outside**.

My basic parts list.....(for standard sheds)
Please check parts carefully and advise immediately if any damage or loss.

		Check List
A	7 x 1830mm Sheets for back 10 x 1600 sheets for roof	A
B	4 x 1960mm Sloping sheets & 4 x 2090mm Sloping sheets for end walls	B
C	1 x 740mm wide sheet with door jamb attached	C
D	Door pre-hinged to 2nd 740mm sheet with door jamb	D
E	4 x 3745 channels for roof 2 x 3000 channels for bottom & 2 x 3045 channels for top of end walls	E
F	4 x 3745 channels with ends cut for Front & Back walls	F
G	4 x 1600mm "L"s for flashing roof to end walls	G
H	2 x 793 Door spacers	H
I	1 x 3770mm Ridge Beam.	I
J	2 x Small & 2 x Large Gable plates for gable ends	J
K	1 x Pack of fixings with padbolt Screws for Zinalume sheds Rivets for Colour sheds 2 x "Z" Door braces	K

Basic overview of what I am trying to achieve...

"For those of us who do not like reading instructions..."

Just join the sheets together and fit the channels to the top and bottom of the sheets as a framing to make 4 walls and the roof. Follow these basic steps:....

- 1. Front Wall:** Layout 2 x (A) 1830mm sheet, (C) sheet with door jamb attached and (D) door with the sheet attached beside them to your preferred configuration and join sheets. Cap the sheets with (F) 3745 channels (2 sided cutout - Top and 1 sided cutout - bottom). Use (H) Door spacers to make sure door fits gap OK (they sit on top of the jambs). Drill & Fix (Rivet or screw) at every 2nd rib. Attach door spacer at each end thru door jambs and channels. 5 fixings underneath into sheeting pan top and bottom. Fit padbolt.
- 2. Back:** Join 5 (A) 1830mm Sheets together. Cap with (F) Channels and fix thru every 2nd rib and at least 1 fixing per sheet thru the back of the channel into the pan of the sheeting. **More in high wind areas.**
- 3. Roof:** Join 5 (A) 1600mm Sheets together. Cap with (E) 3745mm Channels. Fix @ every 2nd rib. Attach (G) 1600 "L"s to ribs at each end of sheeting at corners and 400mm apart in between. Same for 2nd roof panel. Fit Ridge Beam (I) to one of the roof panels and fix through the bottom flange and at ends.
- 4. End walls:** Measure 1523mm to centre of (E) 3045mm channels and cut flanges only (not right through). Join 4 (B) sheets together to form gable wall. Cap with (E) 3000mm channels at bottom and bend 3045 channels over the top. Slip (J) Large Gable plates up under top channel and Small Gable plates underneath in centre of gable and fix to ribs and pans. Fix channels at corners, every 2nd rib in between and in the centre of the gable. 4 fixings up underneath into pan of sheeting and gable plate, top and Bottom. Same for other end
- 5. Assembly:** You have now made up your 6 panels. It's just, Join the corners and put the roof on! Make sure you have at least 6 fixings down each corner when you join the walls. Place, centralise & fix the roof panel that has the ridge beam fitted on thru the "L" into the top channel on both end walls. 1 at each end for now. Place, centre and fix to the other end wall. Slip the 2nd roof panel into ridge beam and fix. Inside: up into ridge beam and outside: thru "L"s every 400mm. You now need to fix down thru every 2nd pan in the roof into the top channels on the front and back walls. **More in high wind areas.** Please make sure that you have removed all swarf filings as the rust spots that they produce may hinder any warranty claims.



- Generally most fixings are spaced at 300mm apart
- Keep fixings in the pans as close to the ribs as possible for added strength.
- Ribs will always protrude to the outside of the shed.
- **Extra** internal fixings is strongly recommended in high wind areas.

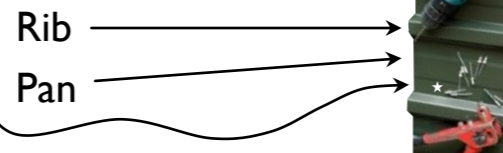

Detailed instructions with diagrams:....

1: Front Wall

You will need:

- (A) 2 x 1830mm sheets
- (C) 740 wide sheet with door jamb
- (D) Pre-hinged door and sheet
- (F) 1 top and 1 bottom Channel
- (H) 2 x Door spacers

Note that the cutouts go to the inside of the panel to allow easy fitment of end walls on assembly

Drawings are diagrammatic and are not necessarily to detail.

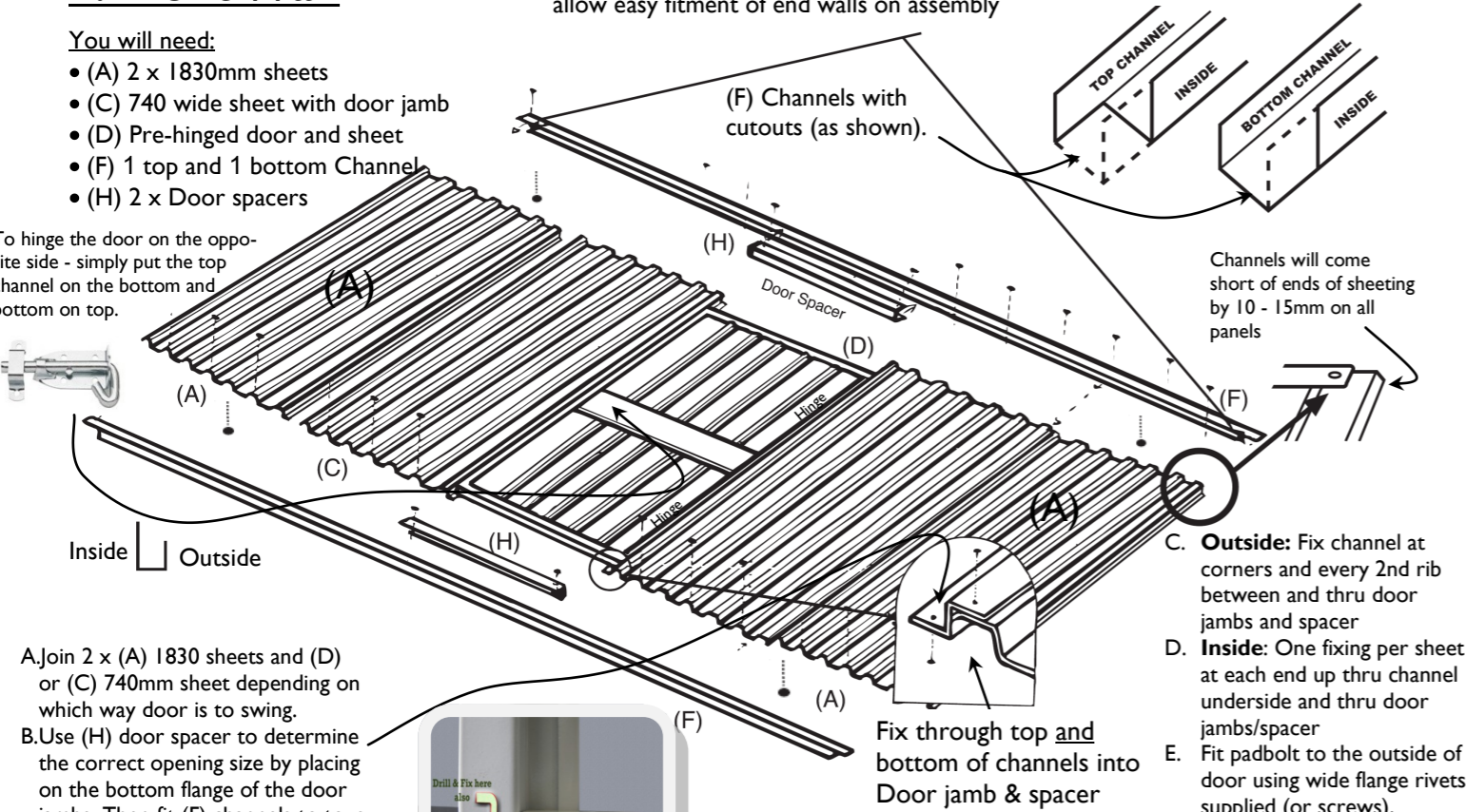

- Join 2 x (A) 1830 sheets and (D) or (C) 740mm sheet depending on which way door is to swing.
- Use (H) door spacer to determine the correct opening size by placing on the bottom flange of the door jambs. Then fit (F) channels to tops and bottoms of sheeting.

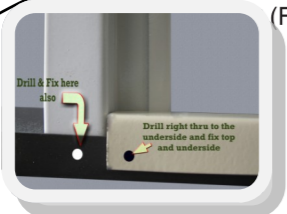

Note: Higher side of channel goes to inside of shed

2: Back Wall

You need:

- 2 x (F) Channels
- 5 x (A) Sheets

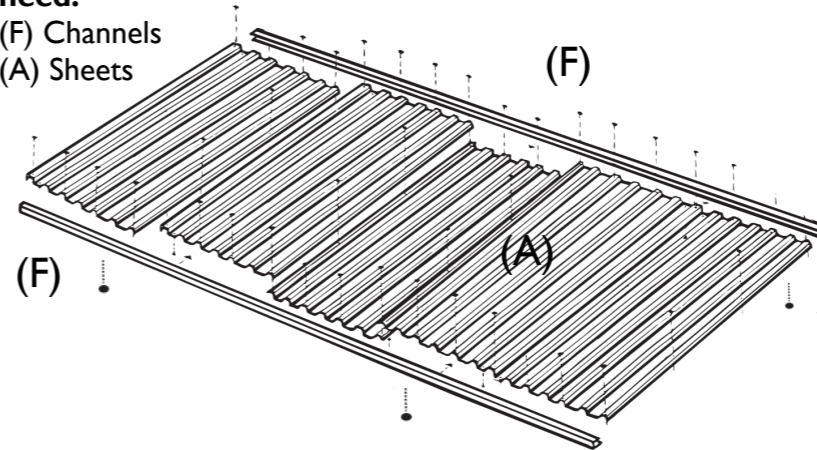

- Join 5 (A) sheets together with 2 fixings thru the overlapping ribs making sure the ends of the sheets are flush.
- Cap sheeting with (F) channels putting the cutouts top and bottom same as the front wall.
- Fix the channels thru the end ribs and every 2nd rib between.
- Make sure you put at least 1 fixing per sheet up thru the underside of the channel into the pan of the sheet.

3: Roof

You need:

- 4 x (E) Channels
- 10 x (A) 1600 Sheets
- 4 x (G) "L"s
- 1 x (I) Ridge beam

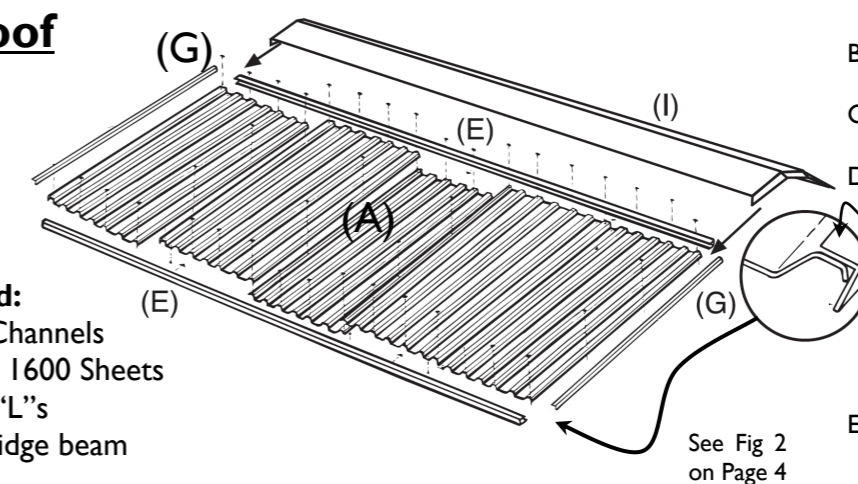

- Join 5 (A) 1600mm sheets together same as the back.
- Cap sheeting with (E) 3745mm channels.
- Fix the channels every 2nd rib but not the corners at this stage
- Place the short flange of (G) "L" on top of the rib at 1 end. Make sure ends are flush with sheeting and put 1 fixing in the centre to hold the "L". Fix the corners thru the channels and 1 more between the corner and the centre fixing. Perform the same at the other end and next roof panel
- Fit (I) Ridge beam to one roof panel and fix thru internal flange and thru the ends of the ridge beam into "L".

See Fig 2 on Page 4

4: End Walls

You need:

- All the (B) Gable Sheets
- 2 x (E) 3000 Channels
- 2 x (E) 3045 Channels
- 4 x (J) Gable plates

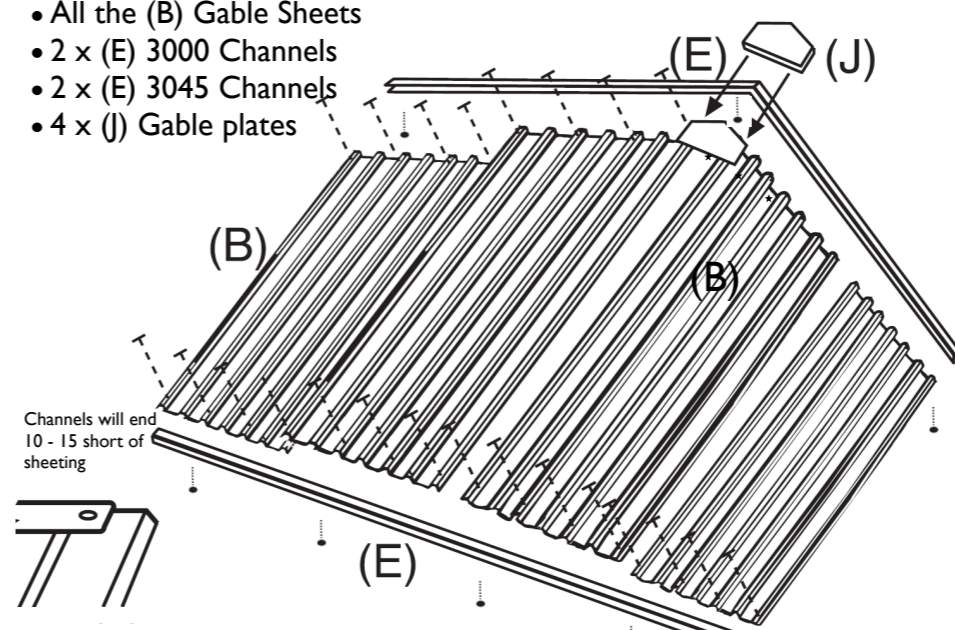

- Join 4 (B) sheets together to give a gable end wall as shown.
- Make a cut in the flanges only at (1523mm) the centre of the 3045 channels
- Cap the bottom of the sheets with a (E) 3000mm channel and bend the cut 3045 channel over the top of the sheets. Fix at corners only for now.
- Slip (J) Large Gable plate under channel at the top and Small Gable plate underneath and fix to sheeting at the *'s
- Fix the channels at every 2nd rib and thru gable plate into sheeting ribs.
- 4 fixings up underneath thru channel into pan of sheet
- Perform the same again for the other end wall.

Door Brace Kit

- The Door braces can be fitted now or after you have assembled your shed.
- Tuck one end of the "Z" between the bottom channel of the inside of the door and the sheet. Do the same at the top overlapping in the centre behind the padbolt. If you have a locking "T" handle you will have to run the "Z"s the opposite way to the diagram.
- Fix the "Z"s at the ends and in the centre to the channel it is tucked under and thru the overlap in the centre. 2 or 3 more rivets will be required thru the door sheeting into the "Z", but they will need to be fixed through from the outside of the door for neater appearance.
- You may need to cut or bend the flange at the bottom and top of the "Z" if it catches on door jamb when opening or closing.

